

Code of Practice for the
**DESIGN, INSTALLATION AND
OPERATION OF UNDERGROUND
PETROLEUM STORAGE SYSTEMS**

Supplement No. 1

**MANAGEMENT OF
EXISTING UNDERGROUND
PETROLEUM STORAGE SYSTEMS**

**Addendum: Health and Safety in
Employment Amendment Act 2002**

Since this document was published the Health and Safety in Employment Act 1992 has been amended by legislation which came into effect from 5 May 2003. While the technical and general information in this document remains current, there may be instances where it does not reflect the changes contained in the amended Act. Your local Occupational Safety and Health Service office can provide further information or you may call:

**Workinfo on 0800 090 0202
www.workinfo.govt.nz**

Acknowledgement

In publishing this supplement, the Occupational Safety and Health Service of the Department of Labour gratefully acknowledges the major contribution made by the oil companies who initiated and co-ordinated its preparation, and also by the Government Agencies, Regional Councils and Territorial Local Authorities who have participated.

The organisations particularly concerned include:

Explosives and Dangerous Goods Division, Department of Labour
Ministry for the Environment
Auckland Regional Council
Environment Waikato Regional Council
Taranaki Regional Council
Wellington Regional Council
Canterbury Regional Council
BP Oil New Zealand Ltd
Caltex Oil (NZ) Ltd
Mobil Oil New Zealand Ltd
Shell New Zealand Ltd

Published by the Occupational Safety and Health Service
Department of Labour
Wellington
New Zealand

Issued June 1995

ISBN 0-477-03566-3

CONTENTS

<i>Section</i>	<i>Heading</i>	<i>Page</i>
1	Introduction	4
2	Objective	4
3	Relationship of this Supplement to the Code	4
4	Additional Definitions	4
5	Management of Potential Risks	5
6	Records	7
7	Potential Risks	7
8	Risk Mitigation	9
9	Response to Product Release	11
10	Application of the Code to Existing Installations	12
11	Appendices	12
Appendix A	Stock Reconciliations	12
Appendix B	Safe Handling of Petroleum Products	18
Appendix C	Observation Well	21
Appendix D	Monitoring Well	22
Appendix E	Spill Container	23
Appendix F	Overfill Device	24
Appendix G	Soil Corrosivity	25

1. INTRODUCTION

This supplement to the code has been prepared to cover underground petroleum storage systems (UPSS) installed prior to the introduction of the code in 1992. It reflects collective experience and expertise in risk management for these tankage systems, and must be read in conjunction with the code, which applies to existing as well as new installations.

This supplement is not intended to be used as a technical specification. It must be supported by detailed technical documentation to obtain approval for any project work from a licensing authority.

2. OBJECTIVE

It is the aim of this supplement to:

- Identify the risks of product release associated with the use of older storage systems.
- Stipulate procedures and equipment for the proper management of existing UPSS.
- Provide UPSS that will store and dispense their contents in a safe, efficient, effective and workable manner.
- Ensure that the possibility of a product release of sufficient magnitude to be hazardous to life, health, property or the environment from any existing UPSS is minimised.

3. RELATIONSHIP OF THIS SUPPLEMENT TO THE CODE

The code covers the design and installation of all new underground petroleum storage systems (UPSS) installed since its publication by the Occupational Safety and Health Service of the Department of Labour in 1992, and also the operation of all UPSS, whether new or existing.

This supplement covering the management of existing UPSS expands on the relevant provisions of the code and applies to all UPSS, including those installed since the publication of the code. It is intended that this supplement be incorporated in the code at its first review which is expected to be no later than 1997.

4. ADDITIONAL DEFINITIONS

For the purposes of this supplement, the code definitions, plus the additional definitions listed below, shall apply.

4.1 Code

The Code of Practice for the Design, Installation and Operation of Underground Petroleum Storage Systems, and amendments thereto.

4.2 Corrosion Expert

A person or organisation having the specialised knowledge and experience needed to design, install and maintain cathodic protection systems.

4.3 Dangerous Goods Regulations

The Dangerous Goods (Class 3 - Flammable Liquids) Regulations 1985, and amendments thereto.

4.4 Existing

An underground petroleum storage system becomes an existing installation as soon as it has been commissioned and remains an existing installation until it has been removed.

4.5 Product

Any petroleum product stored or handled on the site.

4.6 UPSS

Underground Petroleum Storage System

4.7 Zones “A” “B” and “C”

The environmental sensitivity zones described in section 10.1 of the code.

5. MANAGEMENT OF POTENTIAL RISKS

The hazards for the operators, the public, and the environment that may be associated with the storage and handling of petroleum products in underground storage systems arise from:

- Spills
- Leaks
- Fires and explosions.

These can be minimised with good management.

All owners and operators of UPSS must exercise good management, including:

- Sound operating procedures;
- Adequate equipment, properly maintained;
- Supervision to check that good operating procedures are followed and that equipment is maintained;
- Monitoring of product stock to identify any losses that may occur;
- Risk assessment for each and every UPSS site; and
- System up-grading where appropriate.

5.1 Avoiding Spills

Spills are most likely to occur during delivery of product to storage tanks. The person making the delivery must:

- Ensure that there is sufficient space in each receiving tank to hold the amount of product to be delivered;
- Ensure that the delivery hose is connected to the correct fill point, and that hose connections are tight;
- Keep the delivery lines under constant observation during the whole of the delivery; and
- Stop the delivery immediately if any leaks occur. Do not resume delivery until the defect is remedied and it is safe to proceed.

5.2 Avoiding Leaks

Risks of leakage from the system can be minimised by implementing good management systems. Such systems would include site-by-site risk assessment and system upgrading where necessary.

The owner of every UPSS must establish and actively pursue an on-going risk assessment and management system which quantifies the risks of each of the various storage sites, having due regard for each of the release risk and potential impact factors listed in section 7.

High risk sites must be identified and appropriate action taken.

All owners of UPSS must be able to demonstrate to the relevant authorities that they operate soundly-based, on-going risk assessment and management systems. In setting up their systems, owners should refer to the principles set out in documents such as ISO 9000, or to their major supplier of petroleum products.

Whenever circumstances change, the risk assessment for each site must be reviewed to reflect any changes in the original assessment.

5.3 Monitoring for Leakage

Should product leakage occur, it can be identified by following a strict stock reconciliation system (also known as “inventory control”).

Every storage site operator must establish and operate a sound system of stock reconciliation that will identify any losses as they occur. It must be updated regularly—at least daily on busy sites, and no less frequently than fill-to-fill or monthly, whichever is the less, on any other site.

The basic elements of a stock reconciliation system are:

- Measure actual stock in each tank at the beginning of the period (equals opening stock).
- Record all product received into the tank (equals receipts).
- Record all deliveries from the tank (equals sales or throughput).
- Calculate book stock at the end of the period.
- Measure actual stock at the end of the period (equals closing stock).
- Previous period losses/gains shall be considered and carried forward from month to month when assessing trends.

The difference between the book stock at the end of the period and the actual closing stock is the recorded loss or gain. It must be calculated separately for each tank (or pair of coupled tanks). However, petroleum products are volatile, and there will be some vapour losses in handling. Apparent losses can also arise from several factors, including temperature changes and dipping errors. For motor spirits losses of up to 0.5 percent of sales can be expected. Losses of more than 0.5 percent of throughput must be investigated. See also Appendix A — Stock Reconciliation.

Monitoring for the presence of product in observation wells and monitoring wells, where fitted, provides prompt confirmation of suspected leakage. They should be examined for the presence of product or vapour using a bailer or a portable gas analyser. This examination may be carried out at any time by a representative of the owner, or by an authorised officer of the authority. The site operator must

check each well regularly, at least once every month, for any liquid hydrocarbons, and record his observations. See Appendix C—Observation Well and Appendix D—Monitoring Well.

The operator must notify the owner immediately if there is any cause to suspect product loss.

The owner must inform each relevant authority immediately if there is good reason to believe that a product release may have occurred.

6. RECORDS

This section refers particularly to UPSS installed prior to the introduction of the code in 1992.

Where as-builts are not available, general arrangement drawings will be developed.

Information that needs to be readily available on site includes:

- Site layout drawing, including underground tanks, pipework and services.
- Details of secondary containment system, where provided.
- Location of observation wells and monitoring wells.
- Stock reconciliation records.
- Observation and monitoring well monitoring records.
- History of any product releases at site.
- Records of any tank or pipeline test done.
- Records of tests of any cathodic protection installed.

7. POTENTIAL RISKS

The risk of product leakage from a storage system can be considered under two broad categories—the likelihood of product release from the system, and the potential impact on the environment should a leak occur.

7.1 Factors which influence the likelihood of product release include:

- Soil Corrosivity — See Appendix G. For steel tanks and pipework, corrosivity of the soil is a most important factor in determining how long the system will last in the ground.

Fibreglass tanks and pipework appear to be unaffected when buried, even in corrosive soils.

- Age — Field experience shows that there is no absolute limit to the useful life of a steel underground storage tank. Age of a tank installation is only relevant when considered along with soil corrosivity and any corrosion protection provided.

For fibreglass tanks age appears to be a very minor concern as far as potential leakage is concerned.

- Tank coatings and/or jacketing designed to minimise corrosion.
- When a leak occurs, pipework is all too often the source. Underground pipework may be damaged by heavy traffic passing over, and must be protected by adequate load bearing capacity above— e.g. by a concrete slab or by

extra cover depth. It can also be damaged during construction work in the vicinity, but can be protected by first identifying its location and route, and then making sure that all construction work is kept clear of the pipes.

- Cathodic protection systems designed, maintained and monitored to overcome the corrosion problem.
- Double skin tanks, pit liners and HDPE secondary containment systems designed so that leakage from the primary containment can be detected while still being retained by the outer containment system.
- Spill containers retain spillage at fill points and prevent it from seeping away into the ground. See Appendix 5 — Spill Container.
- Overfill preventers give warning when the tank is full and minimise spills when uncoupling. See Appendix F — Overfill Device.
- Site Stability—Pipework and, to a lesser degree, tanks may be damaged by disturbance of the ground due to earthquake or other causes. Soil type, local subsidence and seismic zoning must be considered.
- Dissimilar metals in close proximity or stray currents underground can create an electric potential capable of causing rapid electrolytic corrosion.

7.2 The key factors affecting the impact of a product release are early detection and immediate implementation of the response plan.

Other factors include:

- Effective inventory control which can give early indication of a leak in the system.
- Size of tank — the larger the tank, the larger is the potential release, and the larger impact it can have on the area around the tank.
- Environmental risks near the site.
Environmental Zones “A” “B” and “C” as defined in section 10.1 of the code and established in consultation with the
Regional Councils and territorial authorities cover several factors that have a bearing on the likely environmental impact of any product release. These include proximity to, and possible contamination of an aquifer which is used or intended to be used for potable water supply, or of environmentally sensitive waterways, including coastal waters and wetlands.
- Land use in the immediate vicinity of the site and proximity to underground services which could allow escaped product to spread.
- Soil type/permeability. Will any product released spread quickly, slowly or not at all?
- Viscosity of product. Will any product released disperse quickly, slowly or not at all? |
- Toxicity of product in terms of effects and degree of exposure required to cause those effects.
- Checks for product in observation wells and/or monitoring wells will aid in early leak detection, and can reduce the amount and therefore the impact of any release.
- Pressurised delivery pipework. If pressurised, the amount of product

released should a leak occur may be greater than from unpressurised pipework. However, automatic leak detection is mandatory in pressurised systems and should trigger action by the operator to remedy the situation.

- Location of the non-return valve on the suction system immediately under the dispensing pump will minimise the amount of product released should a leak occur in the suction pipe.
- Continuous automatic leak detection systems for tanks or pipework are designed to prevent any significant release of product.

8. RISK MITIGATION

Acceptable ways of reducing the risk of product release include:

8.1 Stock Reconciliation

So that any discrepancy in stock quantities that could indicate a leak can be found and investigated promptly, an inventory control system must be used, and stocks reconciled frequently. See section 17 and 18 of the code, and section 5.3 above.

Whenever there is a discrepancy greater than 0.5 percent of throughput or a change in the normal pattern in stock reconciliations, it must be investigated quickly and thoroughly.

A standard format should be used for inventory control so that stock movements can be followed day by day. See Appendix A, which gives an example of a stock reconciliation system.

Statistical inventory reconciliation systems may also be used in the analysis of stock loss trends.

8.2 Cathodic Protection

See section 15 of the code.

Where steel tanks or pipework are installed, cathodic protection may be fitted to overcome continuing corrosion.

8.3 Observation Wells

See sections 12.9.3 and 16.1 of the code, and Appendix C.

UPSS may have observation wells installed alongside the tank or tanks.

The first observation well shall always be at the lowest point of the tank excavation.

8.4 Monitoring Wells

See section 16.2 of the code and Appendix D.

Monitoring wells may be installed down groundwater gradient where there are permeable sands and gravel and the highest recorded ground water level is below the tank excavation but within 12 m of ground level.

Monitoring wells may also be required in some highly sensitive areas where ground water level is outside this range, but still reasonably accessible.

The location of wells will be determined after due consideration of relevant site specific factors.

Care must be taken that monitoring wells do not penetrate any significant impermeable layers and provide a route by which a product release may reach groundwater that would not otherwise be affected.

Note: Observation and monitoring wells are to be secured against unauthorised access, and against entry of contaminants either down the side of the well casing or directly into the well.

8.5 Spill Containers

If practicable, spill containers may be installed at tank fill points. See Appendix E — Spill Container.

8.6 Drip Sumps

If practicable, drip sumps should be installed under dispensing units.

8.7 Dip Points

Toby boxes at dip points may be sealed to prevent drips from the dip rod getting into the ground.

8.8 Overfill Protectors

Where not already fitted, overfill protectors may be installed, if practicable, at tank fill points. See Appendix F — Overfill Device.

8.9 Tagging of Fill Points and Toby Boxes

All tank top dip points, direct top and remote fill points, and toby box tops shall be clearly identified by means of permanent markings fixed on or alongside the fitting.

8.10 Monitoring Secondary Containment

All secondary containment systems must be regularly monitored to check for the presence of any product or water within the space between the primary and secondary containment systems. Observations must be noted and a record kept on site.

8.11 Tank and Pipeline Testing

If there is reason to suspect a leak, the owner shall have the whole tank and pipework system checked by applying a proven hydrostatic or other approved test.

“Approved tests” are those tests approved by both:

- The Chief Inspector of Dangerous Goods for use in hazardous areas; and
- The owner, who will only accept tests that have been independently approved by a recognised authority.

Note: Air pressure testing shall not be used in any circumstances.

8.12 Tank or Pipework Removal or Replacement

If found to be leaking, the tank and pipework system shall be removed, repaired or replaced.

9. RESPONSE TO PRODUCT RELEASE

9.1 Emergency Planning

Both the owner and the operator must ensure that an appropriate response plan is in place to deal with any emergency that may arise, including possible spills, leaks, fire and explosion. It is the operator's responsibility to keep a copy on site and to ensure that all staff are familiar with the plan and can implement it promptly in an emergency.

9.2 Response Plans for Product Releases

The response plan for any product release must include the following essential steps, some of which can be taken concurrently:

- Assess the situation.
- Stop the release at source (if possible).
- If there is a fire or spillage that cannot be controlled on site, call the Fire Service.
- Contain the release if possible.
- Put out the fire if possible with extinguishers on site. Do not use water jets as these will spread the fire.
- If product is flammable, but not burning, remove any potential source of ignition.
- Keep the public away.
- Report the release to the relevant authorities and the owner.
- Re-assess the situation.
- Decide on corrective action in conjunction with the authority and the owner, and clean up the released product.
- Do not re-open the site until it is safe to do so.
- Conduct a review of the incident so that lessons may be learnt and a recurrence prevented.

9.3 Additional Information and Guidance

The response plan should also include essential items of guidance and information for easy reference in an emergency.

These should include:

- Agencies/authorities (including phone numbers) to be advised.
- List of spill containment and clean-up equipment available on site, and also from other local and regional sources.
- Assessment of size and extent of the product release, for example:
 - Able to be contained and cleaned up on site by operator and/or owner.
 - Affects off-site areas but can be cleaned up by operator and/or owner.
 - Affects off-site environment and requires other agencies to assist clean up.
- Requirements for disposal of contaminated material.
- Refer to safe handling of petroleum products — See Appendix B.

10. APPLICATION OF THE CODE TO EXISTING INSTALLATIONS

In addition to this supplement, the sections of the code listed below are particularly relevant to existing installations:

- Section 11 — Removal of Tanks
- Section 15 — Cathodic Protection
- Section 16 — Leak Monitoring
- Section 17 — Operation ~'
- Section 18 — Product Loss Investigation
- Section 19 — Leak Testing
- Section 20 — Site Records
- Section 21 — Change of Ownership or Use.

11. APPENDICES

The appendices included in this supplement to the code provide further detail and enlarge on some sections. They must be read in conjunction with this supplement.

Appendix A:

STOCK RECONCILIATIONS

Strict regular and systematic stock control is essential. Accounting for product handled is just as important as accounting for cash handled.

The main steps in accounting for stock are:

1. Measure the product quantity in each tank:
 - Before and after each delivery of product to the site, and
 - At least daily on busy sites.

Each tank should have its own dipstick, calibrated for that tank.

Always check that the dipstick matches the tank in which it is being used.

If the stick is kept in the dip tube of the tank. first remove it, check the product level indication, and wipe the stick dry at and around the liquid level.

Lower the stick slowly and carefully into the dip tube. Do not plunge, it in as this may create a surge in the dip tube. Pause when the stick is within 50 mm of the bottom of the tank to allow any surge to die down, then slowly lower the stick until it just touches the bottom of the tank and withdraw it immediately.

Read the liquid level and record it in a notebook.

Wipe the stick dry at and around liquid level and repeat the measurement.

Check that it agrees with the quantity recorded. If it does not agree, repeat the dip until a consistent result (within 1 to 2 mm on the stick) is achieved. Record this quantity.

If you have difficulty reading the product level on the stick, product-finding paste may be smeared lightly on the face of the stick at and around the liquid level. This will give a clear “cut” on the stick.

2. Check how much water (if any) is in each tank. Any water present will lie in the bottom of the tank (motor fuels all float on water, which readily separates and sinks). It can only be identified by using a water-finding paste, which changes colour when immersed in water. Smear a little water-finding paste on the bottom 100 mm or so of the stick and lower it carefully into the tank. Leave it in contact with the bottom of the tank for about 15 seconds and withdraw.

If you have a clear cut, record the quantity of water in the tank. If you find an indication of water, but no clear cut, try again. If no water is indicated, record “nil”.

Any significant amount of water should be removed from the tank.

3. Check all dispensing equipment meter readings and record. Then check the readings again and make sure they agree with the recorded figures.
4. Enter the figures recorded in the appropriate spaces on the daily stock reconciliation form. Following the instructions on the form, calculate the overs (gains) or unders (losses) for the reconciliation period, taking into account any deliveries received, product used in meter calibration and returned to the tank, any meter replacements, and any other product movement into or out of the tank that might affect the result.
5. Transfer daily overs and unders to the Reconciliation Summary and keep the reconciliation graph up to date.
6. Maintain continuous review of the loss trend shown.

If the trend indicates that losses are consistently in excess of 0.5 percent, you must investigate further.

If you find a sudden large loss or gain, check your arithmetic. If the arithmetic is correct, check the tank dips, and the delivery dockets that record the amounts delivered. If there is still a sudden large loss recorded, it may be theft or a major failure of tank or, more probably, pipework. Are all tank openings sealed and locked? Has there been any recent heavy traffic movement or construction work done in the vicinity of the tank or pipework?

If a tank shows a consistent gain in water, it may be getting in via the tank fittings. Check dip caps and both tank-top and remote fill points to make sure that cap washers are seating properly, and that caps are tight. However, where the water gain is large and sudden, it may have been inadvertently delivered along with a product delivery. If a water gain persists, investigate further.

Whenever there is a significant change in the normal pattern of losses and gains, the operator should advise the owner, and also the supplier, who can offer guidance.

7. Typical reconciliation forms are attached.

Instructions for Pump Meter/Tank Dip Reconciliation

This reconciliation is to be done daily, (preferably at a similar time each day). Details are to be transferred on to a monthly reconciliation summary which shall be held on site.

Wait for a quieter time on the forecourt, or the end of a shift when you may have extra personnel available.

1. Read pump meters and take tank dips.
2. Enter the meter readings under the appropriate product heading and add them down the column. The total of each column becomes the *Total Closing Meters*.
3. Refer to the previous day's reconciliation and take the *Total Closing Meters* amount and enter it in today's *Total Opening Meters*.
4. Any pump testing or meter alterations should be entered in the *Meter Testing* box. Supporting dockets should be attached.
5. Subtract *Total Opening Meters* and *Meter Testing* amounts from the *Total Closing Meters*. The balance should be entered in the *Total Meter Sales* box. *Total Meter Sales* is the actual amount of product that has passed through the pumps.
6. Refer to the previous day's reconciliation and take the *Total All Tanks* amount and enter it in today's *Total Opening Dips*.
7. Enter any deliveries received since the last reconciliation in the *Today's Deliveries* box. Add *Total Opening Dips* and *Today's Deliveries* together and enter this figure as the *Sub Total*.
8. Enter *Total Meter Sales* figure from above and subtract from the *Sub Total*. *Calculated Closing Dips* are the theoretical amounts that should be in the tanks.
9. Enter today's tank dip readings and the time the dips were recorded. Add them down the column and enter the figure in the *Total All Tanks* box.
10. Enter *Calculated Closing Dips* amount from above and subtract from *Total All Tanks*. Enter this amount in *Today Over/(Under)* box. (If the figure is a negative, it is an under and should have brackets around it to indicate this.) *Today Over/(Under)* is the difference between the amount of fuel that should be in your tanks compared with what is actually in your tanks.
11. Refer to the previous day's reconciliation and take the *Year To Date Over/(Under)* and add/subtract it to *Today's Over/(Under)*.

Enter this figure in the *Year To Date Over/(Under)* box.

This is the total loss or gain year to date on your site for each product.

Appendix A (cont)

PUMP METER/TANK DIP RECONCILIATION

*Must be completed between 8 and 24 hours after each delivery or when a pump or the tote is changed.
Meter testing, pump or tote changes should be supported by fitter's documentation.*

Site: _____ Date: ___/___/___

Time Dips Recorded: _____

(Important: Dips and meters should be read at the same time)

Super 96

Unleaded 91

Diesel

METERS	Pump	1			
		2			
		3			
		4			
		5			
		6			
		7			
		8			
		9			
		10			
		Total Closing Meters			
	less Total Opening Meters				
	<i>(These will be 'Total Closing Meters' from previous day's reconciliation)</i>				
	less Meter Testing				
	<i>(or any product returned to tanks)</i>				
	= Total Meter Sales				
CALCULATED TANK DIPS	Total Opening Dips				
	<i>(These will be "Total All Tanks from previous day's reconciliation)</i>				
	plus Today's Deliveries				
	= Sub Total				
	less Total Meter Sales (as above)				
= Calculated Closing Dips					
	<i>(What should be in the tanks)</i>				
ACTUAL TANK TANK DIPS	Tank 1				
	2				
	Enter Water dip test beside tank No.				
	Note: Water dips must be taken				
	at least weekly.				
	4				
	Total all Tanks				
less Calculated Closing Dips					
= Today's Over/(Under)					
= Year to Date Over/(Under)					
<i>Combine previous day's "Year to Date" balance</i>					

Prepared by: _____

INSTRUCTIONS FOR RECONCILIATION SUMMARY

This form should be updated each day in conjunction with the Pump Meter/Tank Dip Reconciliation form.

1. Enter the date, *Total Meter Sales* and *Today Over/(Under)* figures from the reconciliation sheet.
2. At the end of each seven-day period, total each column and enter this amount in the *Weekly Total* box.
3. At the end of the month, add down the column each amount in the *Weekly Total* boxes, and enter this figure in the *Monthly Total*.

Note: Remember that amounts appearing as an (under) are a negative amount, and should be subtracted.

4. At the end of each week, plot the *Weekly Over/(Under) Variance* total figure on the graph at the appropriate place.

The resulting monthly graphs, will provide an easy-to-see summary of the *Overs/Unders* for the site.

RECONCILIATION GRAPH

Product Grade
Weekly Over/Unders

Site: _____ Month: _____

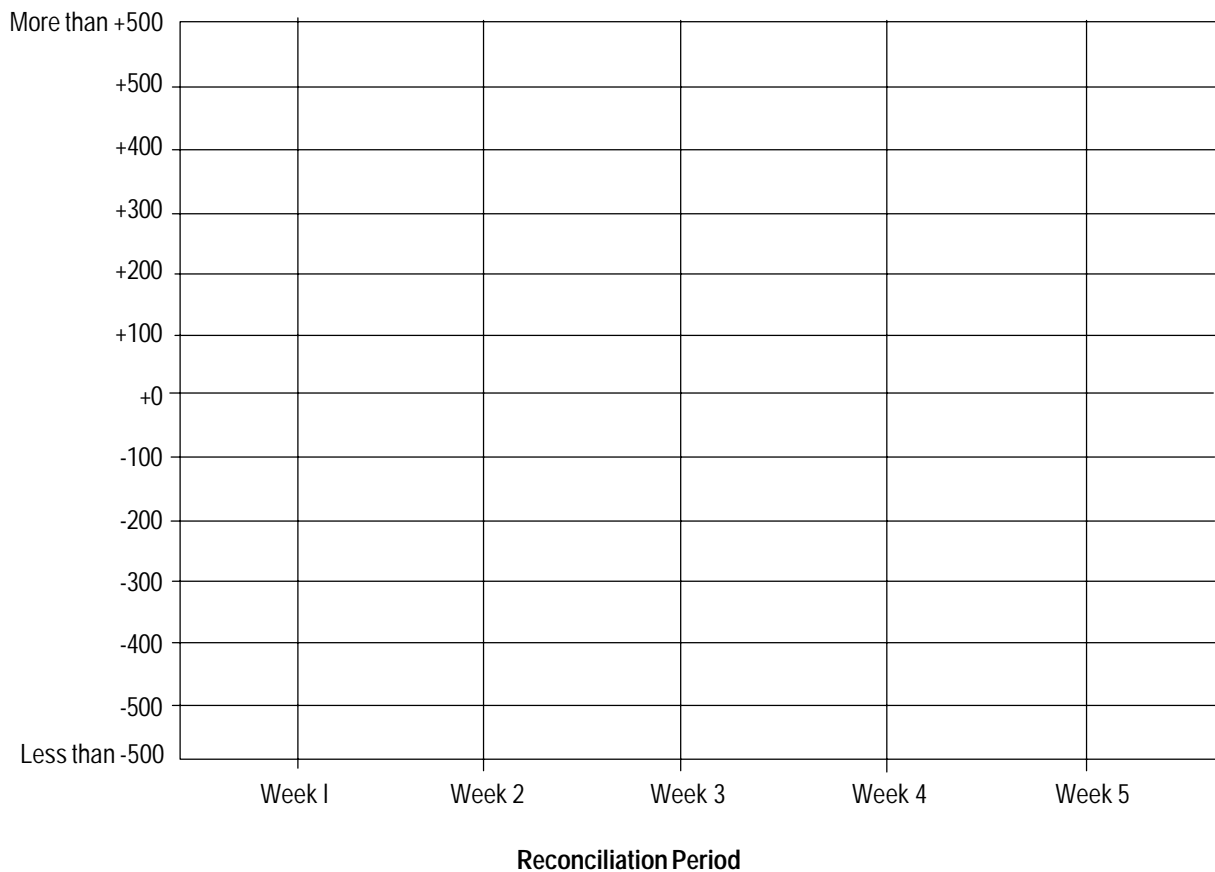

RECONCILIATION SUMMARY

Super 96

Site _____

Month _____

Date	Daily Total Meter Sales	Daily Over (Under) Variance
Weekly Total		
Weekly Total		
Weekly Total		
Part Week Total		
Monthly Totals		

Stock Variance

Prepared by: _____ Notified to: _____ Date: ___/___/___

Appendix B

SAFE HANDLING OF PETROLEUM PRODUCTS

General

All petroleum products are hazardous. They can cause EXPLOSION or FIRE.

Most petroleum products are TOXIC when not used with due care.

Fire and Explosion

All petroleum products must be treated as being potentially explosive, even in small quantities.

Petrol, aviation gasoline and most solvents evaporate readily, producing an explosive mixture with air. Kerosine, aviation turbine fuel and the less volatile solvents can also produce explosive vapours, particularly in poorly ventilated areas. All products can accumulate static electricity which may trigger an explosion — kerosine type products are particularly susceptible.

Automotive diesel, fuel oils and lubricating oils can produce explosive conditions if sprayed or heated, even over small areas.

Precautions Against Fire and Explosion

Keep all SOURCES OF IGNITION away from petroleum products and their vapours. Sources of ignition include:

- Matches, lighters and cigarettes, etc.
- Any flame or spark.
- Any non-flameproof electrical equipment, including switches, hand torches, electric radiators, vacuum cleaners, power tools and radios.
- Welding sets, leads, connections and hand-pieces.
- Gas welding torches.
- Motor vehicles and all internal combustion engines.
- Tools which can cause a spark if dropped, etc.
- Grinders.

Petroleum vapours are heavier than air and will readily collect in pits, drainage sumps, cellars, and any low areas. Small quantities of vapour can be quickly and safely dispersed by good and rapid ventilation.

- The presence or absence of petroleum vapours can be checked by a competent operator using an explosimeter.
- Do not enter any tank or pit that has contained or does contain petroleum products unless it has first been tested and a safety certificate issued by a competent person.
- **Do not do any hot work** (e.g. welding, gas cutting, grinding, drilling or power wire-brushing) on any tank or container that still contains any product or that has not been tested and certified gas free by a competent person.

- **Do not transfer or pour petroleum products** from one container to another, without ensuring that both containers are fully earthed, and that an effective earthing connection is made between hose nozzle and receiving container before any transfer is started, and is maintained as long as the transfer continues.

Toxic Hazards

Petroleum vapours can quickly asphyxiate. At lower concentrations, they irritate the eyes and lungs, and may cause nausea, headache and depression.

Petroleum products will irritate the eyes and skin and may cause dermatitis on prolonged or repeated contact.

In addition, high octane petrol and aviation gasolines contain toxic lead compounds. Internal surfaces of tanks which have contained these products will be contaminated and must be treated as highly toxic, even after all product has been removed.

Precautions Against Toxic Hazards

- Avoid splashing, or any contact with the eyes or skin.
- Wear PVC gloves and boots, and cotton overalls. Wear goggles or face shield if splashing is possible.
- If clothing gets contaminated with product, remove under a running shower.
- If eye or skin contact occurs, treat as under First Aid Treatment on page 20 of this supplement.

Notes for Physician

Administration of medicinal liquid paraffin may reduce absorption through the digestive tract. Gastric lavage should only be done after endotracheal intubation in view of the risk of aspiration which can cause serious chemical pneumonitis for which antibiotic and corticosteroid therapy may be indicated. Motor gasolines may contain lead compounds, however, the quantities involved are unimportant in the context of the treatment of acute gasoline poisoning.

EMERGENCY ACTION

Case of Petroleum Spillage

- If a spill occurs, extinguish all naked flames.
- Shut down any other potential sources of ignition.
- Ensure area is well ventilated.

Small Spill: Absorb spills in enclosed areas. Absorb outside spills using sand, earth, or a proprietary absorbent.

Large Spill: Contain and pump into storage.

Petroleum Fire

- Use dry powder, foam, B.C.F., or Carbon Dioxide extinguishers.
- Do not use water jets — these will spread the fire.

First Aid Treatment

Petroleum Products Swallowed

- DO NOT INDUCE VOMITING! The main hazard following accidental ingestion is aspiration of the liquid into the lungs, and children are more susceptible than adults.
- Give 300mls (1/2 pint) of milk to drink; if not available, give water.
- SEND TO THE HOSPITAL IMMEDIATELY.

Eye Contact

- Wash with copious amounts of water for at least 10 minutes.

Skin Contact

- Drench the skin immediately with cold water.
- Remove contaminated clothing under a running shower and wash all contaminated skin with soap and water.

Inhalation

- Move victim to fresh air.
- Keep the patient warm and at rest.
- If unconscious, place in the recovery position.
- If patient is not breathing, give artificial respiration.
- Give cardiac massage if necessary.
- SEND TO THE HOSPITAL.

Medical Treatment

See Notes for Physician on page 19.

Appendix C OBSERVATION WELL

Observation wells can be used close to a tank or group of tanks as a means of detecting leakage where a separate secondary containment system is used, or where the ground is sufficiently impervious to hold back any product that has escaped.

The observation well is a slotted pipe sunk into the ground surrounded by sand or pea gravel, and fitted inside a toby box so that it is accessible for inspection and sampling if necessary.

Typical details are shown below.

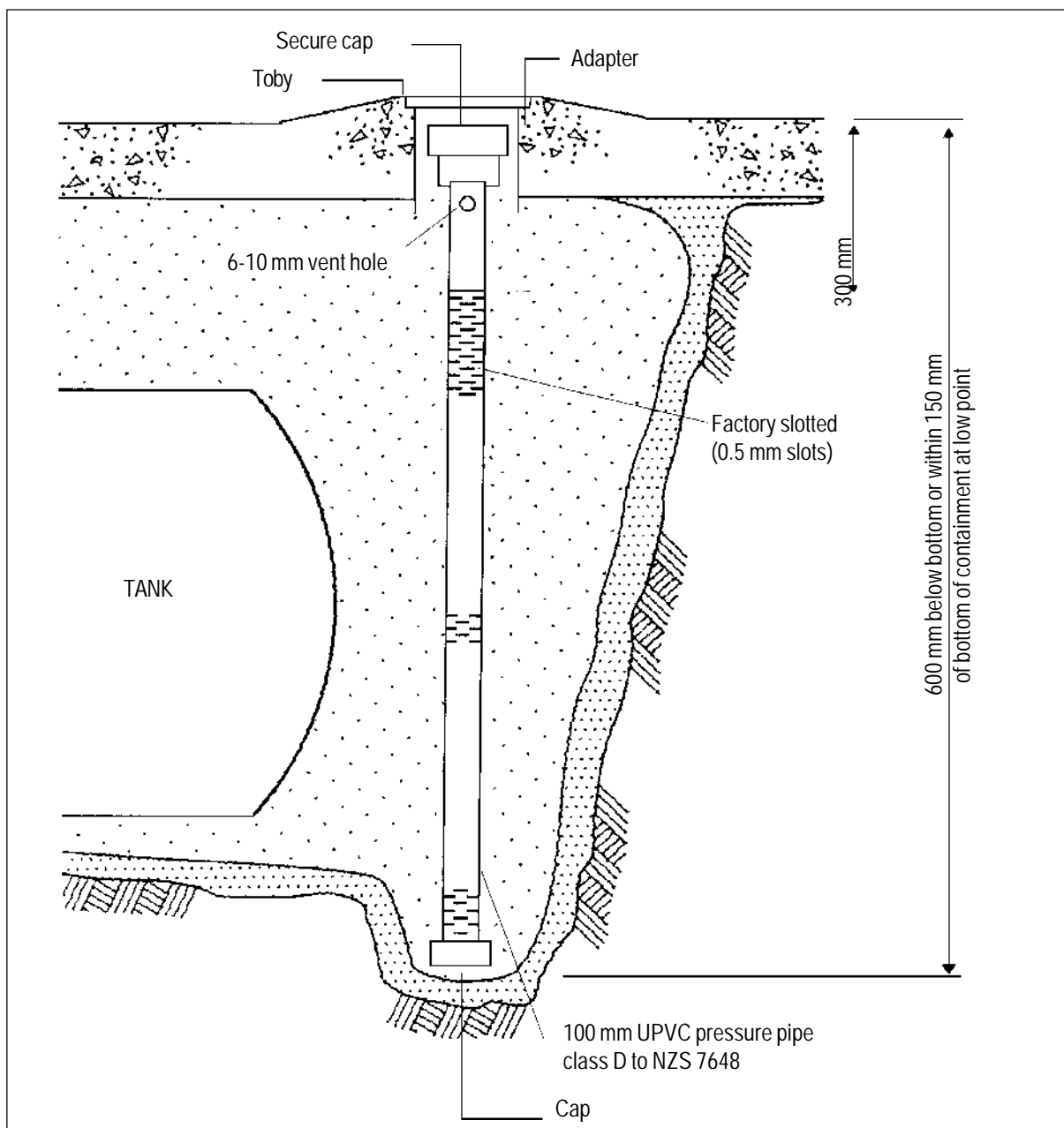

Check observation wells for liquid products using a weighted bailer or a thief pump.

A vapour tester is needed to check for petroleum vapour.

Appendix D MONITORING WELL

Monitoring wells are used to monitor the surface of the ground water in the general area of an underground tank or group of tanks for any sign of petroleum products on sites where the soil is permeable and there is no secondary containment.

Typical details are shown below.

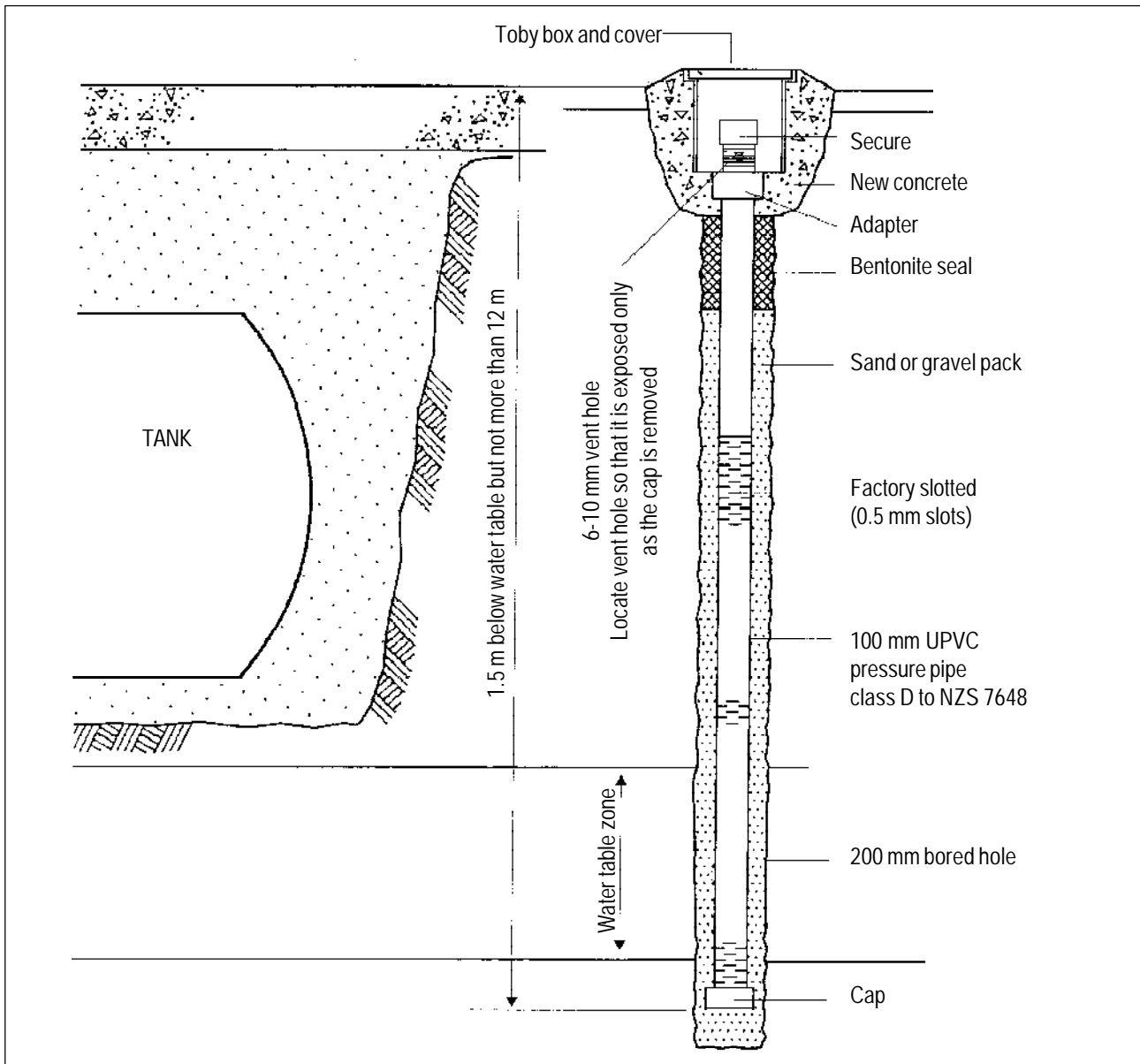

Check monitoring wells for liquid products using a weighted bailer or a thief pump.

A vapour tester is needed to check for petroleum vapour.

Appendix E SPILL CONTAINER

The spill container is a device that may be fitted at the fill point connected to an underground tank.

It is designed to catch any product that may spill from the hose during delivery or uncoupling. It also provides for the retained product, if uncontaminated, to be dumped into the tank. If the product has become contaminated, it can be pumped or bailed out into an earthed container for appropriate disposal off-site.

Typical details are shown below.

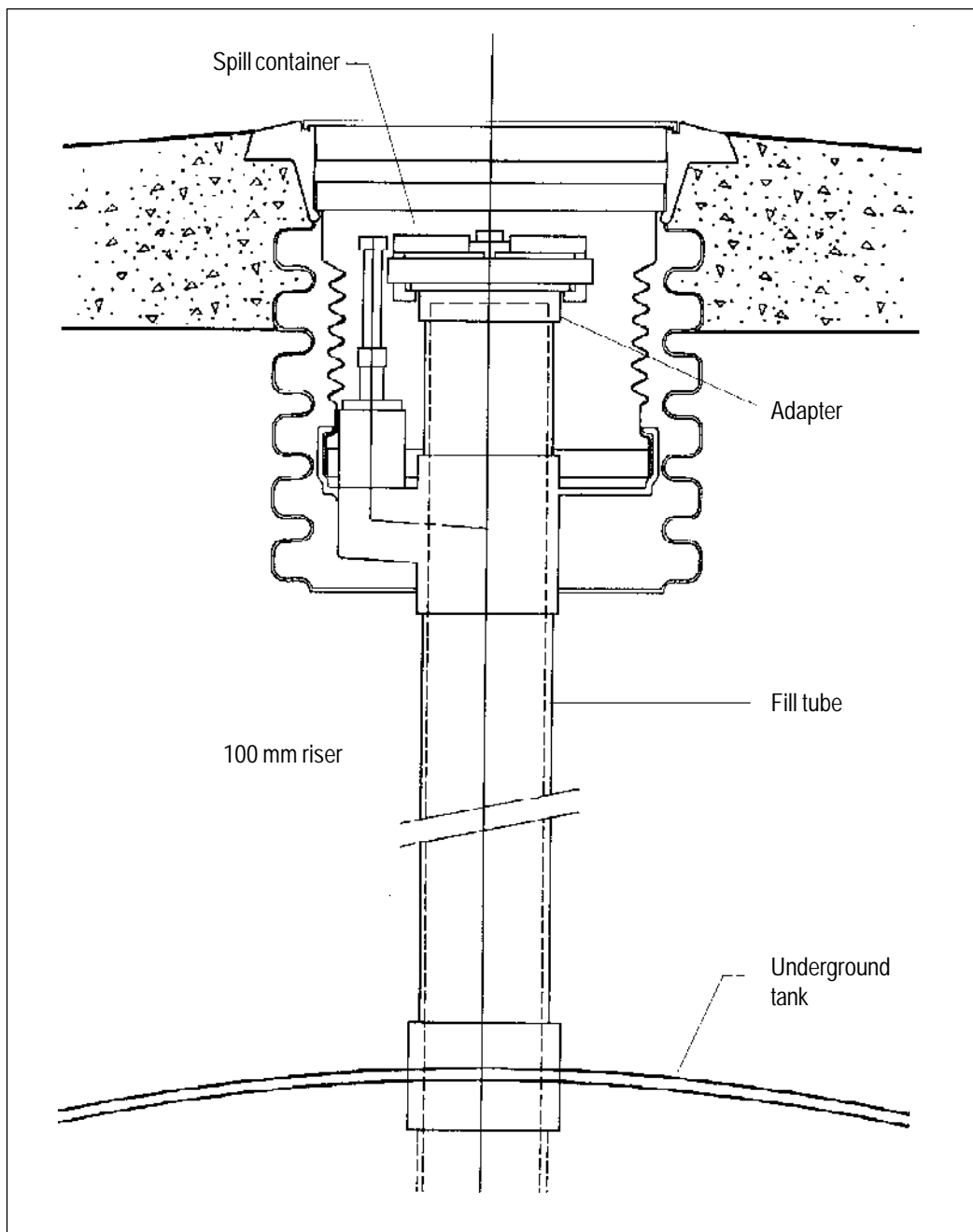

Appendix F OVERFILL DEVICE

The overflow protection device is designed to reduce the flow rate during delivery of product into a tank to a trickle as soon as the product surface in the tank reaches a predetermined high level.

This is achieved by using a pivoted float to trip the closing of a check valve. The device resets itself as product level in the tank falls again.

Typical details are shown below.

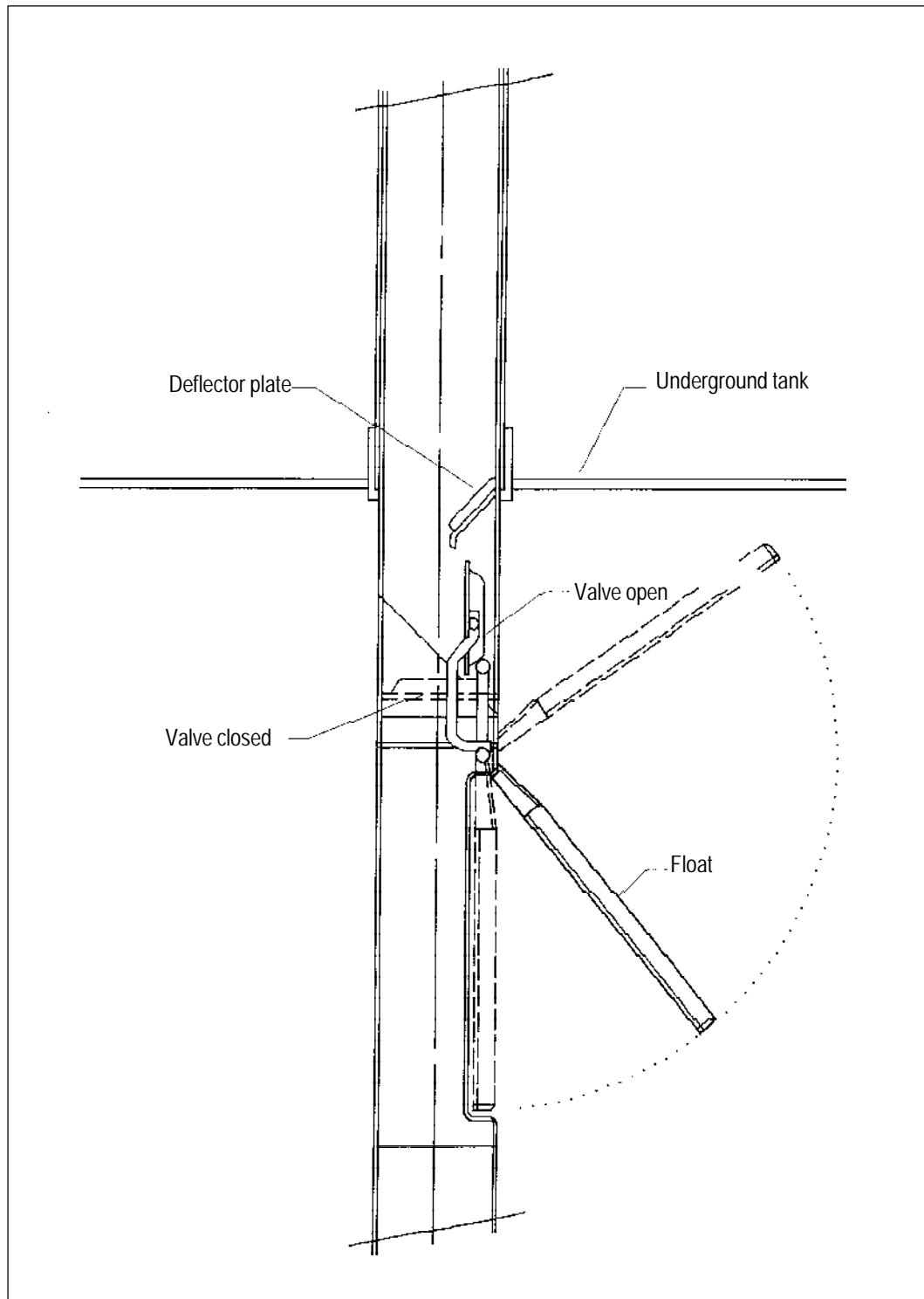

Appendix G

SOIL CORROSIVITY

Soil corrosivity can only be assessed by considering all the soil qualities that contribute to the rate of corrosion of buried metal structures. These factors include:

- Resistivity — low resistivity favours corrosion while high resistivity (over say 15,000 ohm/cm) reduces the likely rate of corrosion;
- pH;
- Composition of dissolved salts;
- Moisture content and fluctuation of groundwater level;
- Presence of sulphate reducing bacteria;
- Degree of aeration;
- Presence of abnormal constituents in soil such as:
 - Mineral ores,
 - Ash cinders or other corrosion-inducing substances,
 - Sewage effluents;
- Stray electrical currents — direct or alternating;
- Temperature and temperature fluctuations;
- Thermal activity.

Soil corrosivity should only be assessed by a corrosion expert.